

HAFCO METALMASTER

PORTABLE BAND SAW OPERATION MANUAL

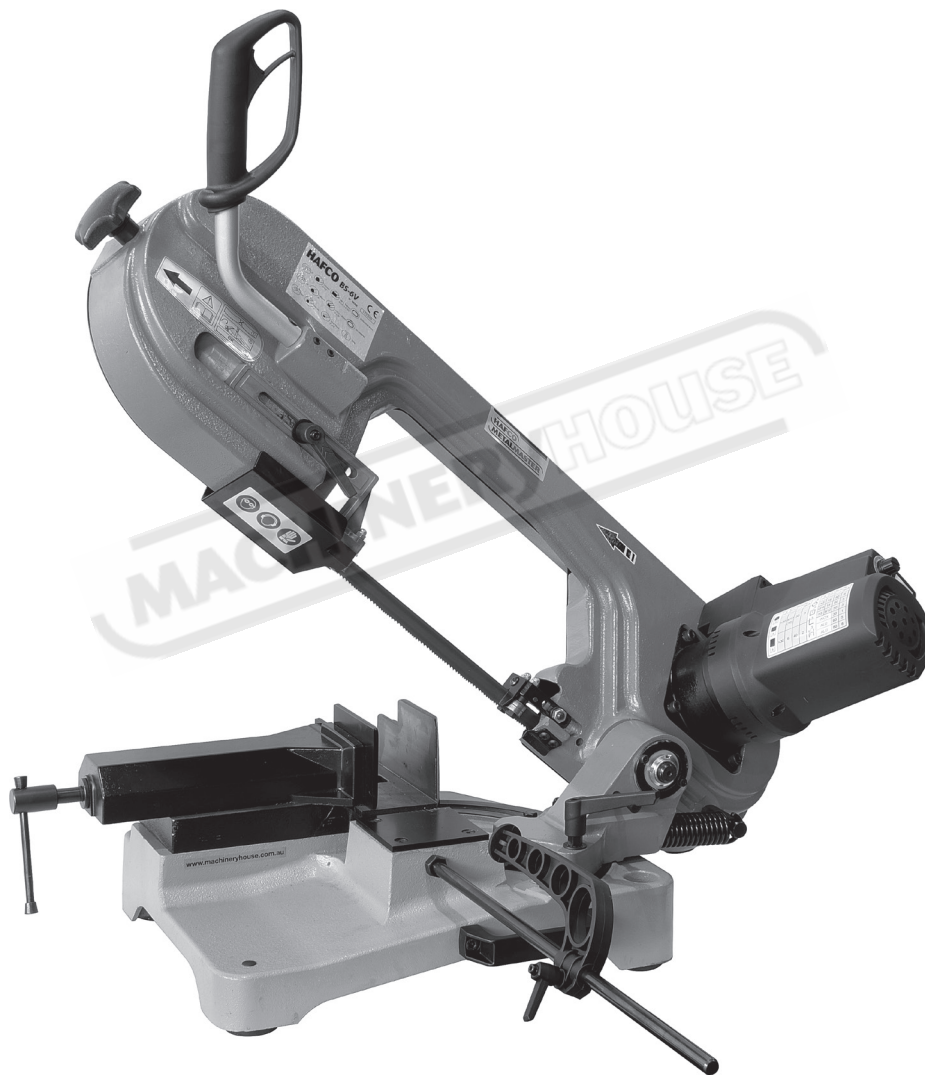

Model BS-6V

Edition No : BS-604

Date of Issue : 05/2018

www.machineryhouse.com.au



OPERATION MANUAL

MACHINE DETAILS

MACHINE	<input type="text" value="PORTABLE BAND SAW"/>
MODEL NO.	<input type="text" value="BS-6V"/>
SERIAL NO.	<input type="text"/>
DATE OF MANF.	<input type="text"/>

Distributed by



www.machineryhouse.com.au

www.machineryhouse.co.nz

Note:

This manual is only for your reference. Owing to the continuous improvement of HAFCO machines, changes may be made at any time without obligation or notice. Please ensure the local voltage is the same as listed on the specification plate before operating any electric machine.



NOTE:

In order to see the type and model of the machine, please see the specification plate.

PRODUCT IDENTIFICATION

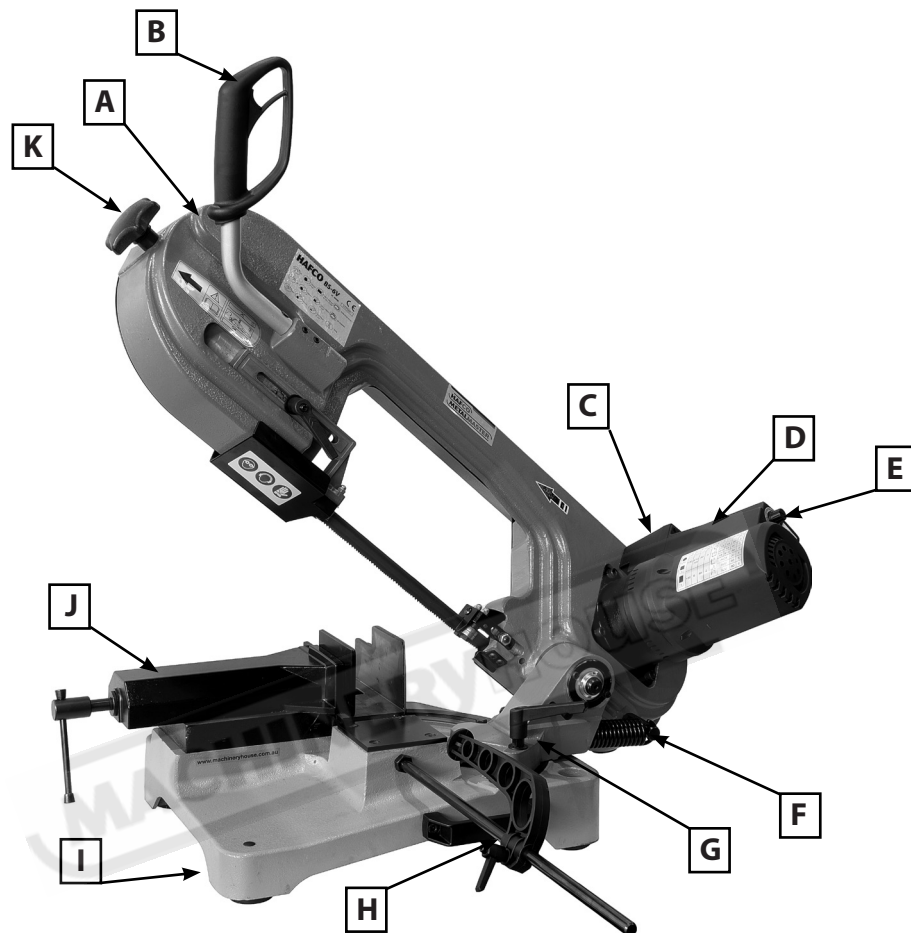

Fig. 1

Become familiar with the names and locations of the controls and features shown below to better understand the instructions in this manual.

A. BOW FRAME: Main movable structure that supports the blade and motor.

B. SWITCH HANDLE: Trigger switch operates the machine when held.

C. MAIN SWITCH: Main power ON/OFF switch

D. MOTOR: Motor used to drive the blade

E. VARIABLE SPEED CONTROL: Adjusts the speed of the blade.

F. FRAME SPRING: Return spring to raise the blade after the cut.

G. ANGLE CLAMP: Clamps the bow frame after the angle has been set

H. MATERIAL STOP: Used to set the length of the material to be cut.

I. BASE: Main base and support of the machine

J. VICE: Used to clamp the material to be cut.

K. BLADE TENSION KNOB: Applies tension to the blade.



OPERATION MANUAL

SAFETY RULES

1. ALWAYS DISCONNECT FROM POWER. Always remove the plug from the wall socket before any adjustments, maintenance, or blade changes are made.
2. REMOVE ADJUSTING KEYS AND WRENCHES. Form a habit of checking to see that keys and adjusting tools are removed from tool before turning it on.
3. KEEP WORK AREA CLEAN. Cluttered areas and benches invite accidents.
4. DON'T USE IN DANGEROUS ENVIRONMENT. Don't use power tools in damp or wet locations, or expose them to rain. Keep the work area well lit
5. KEEP CHILDREN AWAY. All visitors should be kept a safe distance from work area.
6. MAKE WORKSHOP KID PROOF with padlocks, master switches, or by removing starter keys.
7. DON'T FORCE TOOL It will do the job better and safer at the rate for which it was designed.
8. USE RIGHT TOOL do not force the tool or attachment to do a job for which it was not designed.
9. USE PROPER EXTENSION LEAD. Make sure your extension lead is in good condition. When using an extension lead, be sure to use one heavy enough to carry the current your machine will draw. An undersized cord will cause a drop in line voltage resulting in loss of power and overheating. The correct size to use depends on the extension lead length and the ampere rating, which should be greater than the amperage found on the tool nameplate. If in doubt, use the next heavier lead
10. WEAR PROPER APPAREL do not wear loose clothing, gloves, neckties, rings, bracelet or other jewelry. Contain long hair, which may get caught in moving parts. Non-slip foot wear is recommended. Wear protective hair covering
11. ALWAYS USE SAFETY GLASSES AND EAR PROTECTION. Also use face or dust mask if cutting operation is dusty. Everyday eyeglasses only have impact resistant lenses, they are NOT safety glasses.
12. SECURE WORK. Use clamps or a vice to hold work when practical. It's safer than using your hand and it frees both hands to operate tool.
13. DON'T OVERREACH. Keep proper footing and balance at all times.
14. MAINTAIN TOOLS WITH CARE. Keep tools sharp and clean for best and safest performance. Follow instructions for lubricating and changing accessories.
15. DISCONNECT TOOLS before any servicing; or when changing accessories, such as blades, bits, cutters, etc
16. REDUCE THE RISK OF UNINTENTIONAL STARTING. Make sure the switch is in the off position
17. USE RECOMMENDED ACCESSORIES. Consult the owner's manual for recommended accessories. The use of incorrect accessories may cause risk of injury to persons.
18. NEVER STAND ON TOOL Serious injury, could occur if the tool is tipped or if the cutting tool is unintentionally contacted.
19. NEVER USE BLADES WHICH ARE DAMAGED OR DEFORMED.
20. NEVER CLEAN THE SAW BLADE WHILST IT IS IN MOTION

OPERATION MANUAL

SAFETY RULES Cont.

21. CHECK DAMAGED PARTS. Before using the tool, check guards or other parts to see if they are damaged. If damaged carefully check to determine that the tool will operate properly and perform its intended function. Check for alignment of parts, moving parts are not binding, parts are not broken and correctly mounted, or any other condition that may affect the tools operation. Any guard or other part that is damaged should be properly repaired or replaced
22. DIRECTION OF FEED. Feed work into a blade or cutter against the direction of rotation of the blade or cutter.
23. NEVER LEAVE TOOL RUNNING UNATTENDED. TURN POWER OFF. Do not leave the tool until it has come to a complete stop. If fitted, lock the main switch in the OFF position, remove the switch key from the switch. Place the key in a location that is inaccessible to children and others not qualified to use the tool.



- Wear eye protection.
- Do not remove offcuts that have been jammed until blade has stopped.
- Maintain proper adjustment of blade tension, blade guides, and thrust bearing.
- Adjust upper guide to just clear workpiece.
- Hold workpiece firmly against table

MATERIAL TO BE CUT

The machine is intended to cut material such as steel, Iron, copper, etc. **Never use this tool to cut wood and explosive metal material.**

USE A CORRECT PLUG

Different countries use different plugs. The correct approved plug must be installed by a qualified electrician.

GROUNDING INSTRUCTIONS

In the event of a malfunction or breakdown, grounding provides a path of least resistance for the electric current reducing the risk of electric shock. This tool is equipped with an electric cord that has an equipment-grounding conductor and a grounding plug. The plug must be plugged into a matching outlet that is properly installed and grounded in accordance with all local codes and ordinances.

Do not modify the plug provided - if it will not fit the outlet, have the proper outlet installed by a qualified electrician. Improper connection of the equipment-grounding conductor can result in the risk of electric shock. The grounding wire must have an insulation that has an outer surface that is green, with or without yellow stripes. If the cord is repaired or replaced or the plug needs replacing, a qualified electrician must be used to make the change.



OPERATION MANUAL

RUNNING IN THE BLADE

To safeguard the life and quality of a new blade, the first two or three cuts must be made exerting slight pressure on the workpiece so that the cutting time is almost twice the length of time normally needed. Blade information can be found by checking with the blade supplier.

CORRECT POSITIONING OF THE PIECE IN THE CLAMP

Pieces to be cut must always be held firmly in the clamp, directly between the two jaws and without inserting other objects. Where profiles, flat bars or particular shapes are to be cut, refer to the examples in Fig .B

To cut a long work piece, use a roller stand to support it.

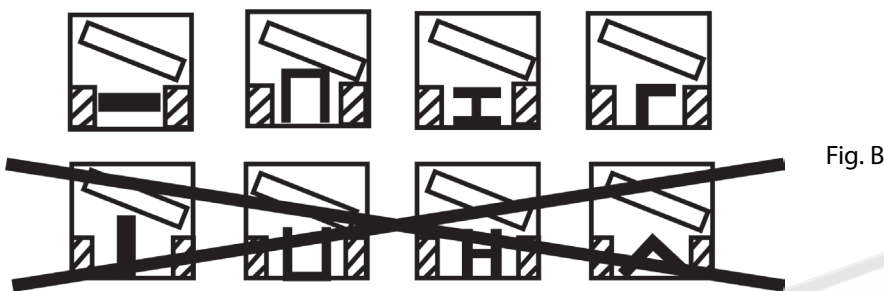

BLADE SELECTION





Before operation, proper blade selection should be made for the type of material to be cut. The proper blade can be chosen, using a tooth per inch (tpi) rating system. You must consider the material being cut and its diameter when choosing the correct blade. The chart below (Fig. C) will help with the selection. Your band saw is fitted with a 2035mm x 19mm, 0.9mm thick metal blade.

Blade choice based on material:

- Soft material (aluminum, lead, rubber) use a 14 tpi blade.
- Hard material (steel, cast iron) use a 24 tpi blade.
- Soft and hard material use an 18 tpi blade.

Blade choice based on diameter:

- For thick material use a 14 tpi blade.
- For thin material use a 24 tpi blade.
- For thick or thin material use an 18 tpi blade.

	30mm 50mm 115 max	8-12 tpi 6 tpi 6 tpi		30 x 2.5mm 40 x 3mm 50 x 4mm	14tpi 14tpi 8 - 12 tpi
	30mm 40mm 115 max	8-12 tpi 6 tpi 6 tpi		30 x 2.5 50 x 3mm	14 14
	25 x 35mm 40 x 50mm 115 x 153mm	8-12 tpi 6 tpi 6 tpi	Fig. C		

CHANGING THE BLADE

To remove the blade:

1. Unplug the band saw from the power source!
2. Release tension on the blade by turning the tension control handle to loosen.
("K" Fig. 1 on Page 3)
3. Raise band saw bow and unscrew the Phillips head screws to remove the back cover.
(Fig. D)
4. Remove the blade from between the blade guide bearings.
5. Open the wheel covers and slide the blade off one wheel at a time. **Use caution — the blade is sharp!**
6. Place one end of the new blade over the drive pulley of the band saw. (Fig. F)
7. Feed the other end of the blade around the idle pulley and roll the blade onto the track.
8. Make sure the back of the blade is in contact with the guide bearings that support the back of the blade (Fig. E).
9. Re-tension the blade using "K" Fig.1 Page 3

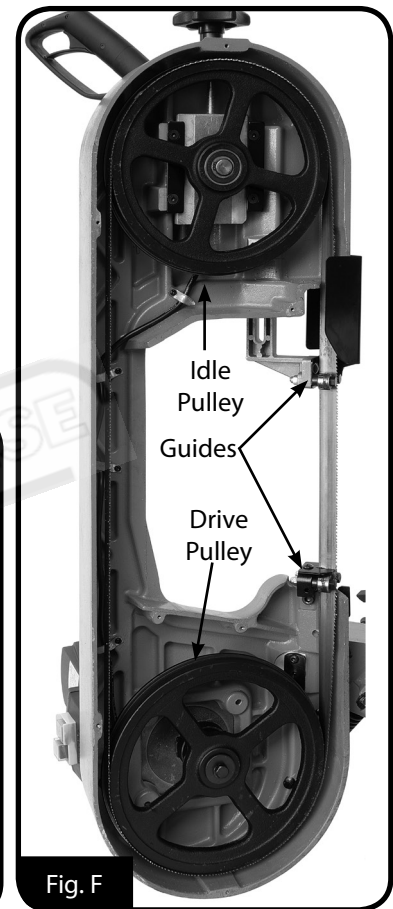
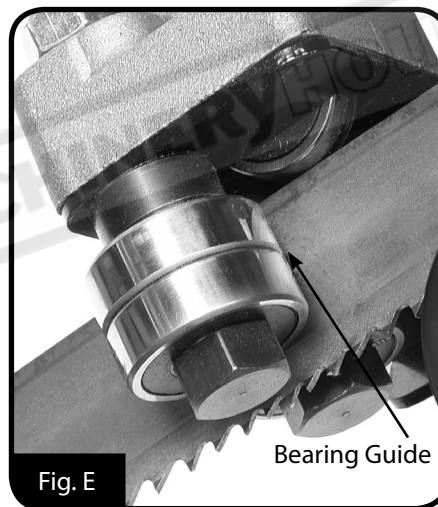

BLADE SPEEDS

When using your band saw, always change to the blade speed recommended for the material and the size of the material to be cut. If in any doubt, check the speed required with blade supplier)

To change the blade speed on your band saw

1. Make sure the blade is running and tracking correctly.
2. Make sure the saw blade is NOT engaged in the workpiece.
3. Check the material you are cutting and determine the proper blade speed setting by viewing the chart found on the side of the motor.(Fig. G)
4. Move the blade speed control dial (Fig. G) to the position recommended on the chart.

NOTE! The speeds on the chart are a recommendation only and may vary depending on the individual application.



OPERATION MANUAL

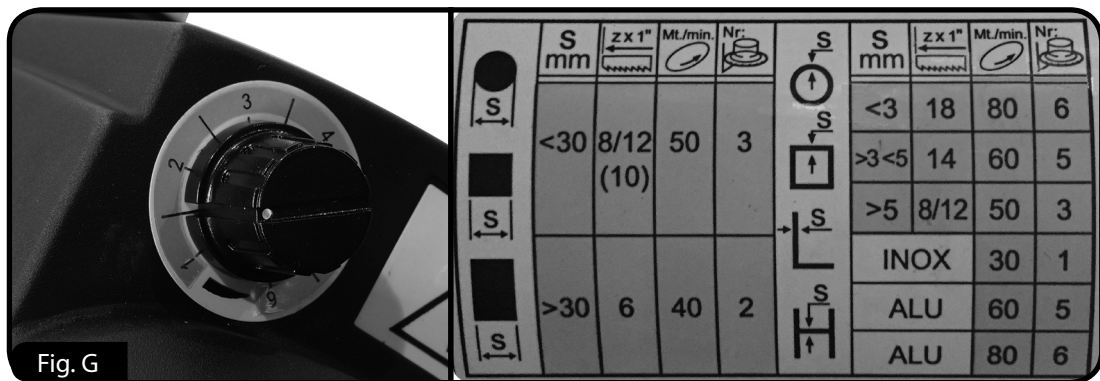

Fig. G

ADJUSTING THE CUTTING ANGLE

The band saw can cut an angle varying from 0° to 60°. Loosen the locking handle (L of Fig. H) and Turn the bow until the scale (M in Fig. H) is set to the desired angle, then tighten the locking handle.

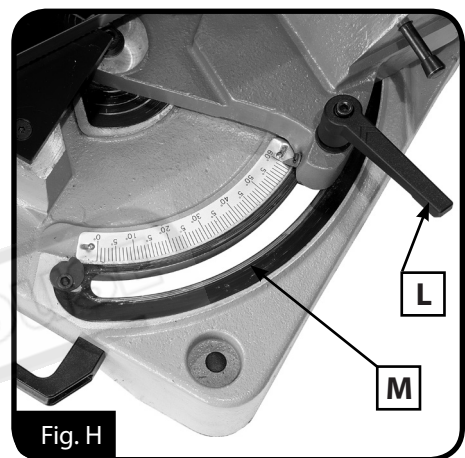

Fig. H



Fig. I

OPERATION

To power the machine push in the ON switch (Fig. I) Then press and hold the trigger (N of Fig J) to start cutting.

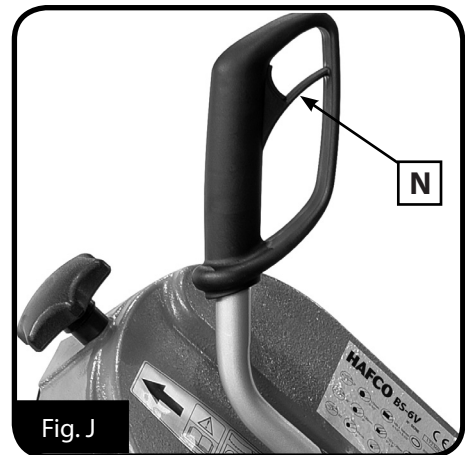

Fig. J

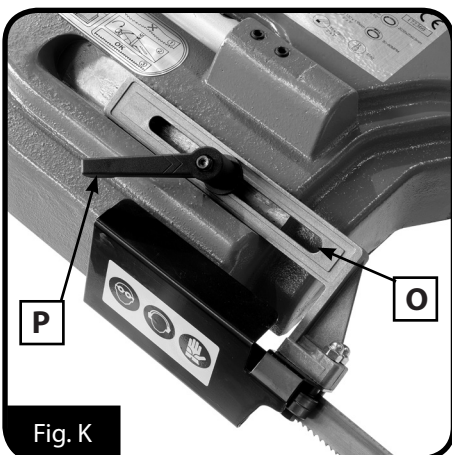

Fig. K

ADJUSTING THE BLADE GUIDE

Disconnect the machine from the power supply

Your cutting machine is provided with a sliding guide (O of Fig. K) with built-in protection, which guides and gives rigidity to the part of the blade necessary to make the cut, To do this, simply loosen the locking handle (P of Fig. K) and slide the blade guide so as to bring it closer or further from the piece that is to be cut.

OPERATION MANUAL

MAINTENANCE

1. DISCONNECT POWER SUPPLY: Be careful before every cleaning or maintenance operation, to ensure that the electric supply socket is removed.
2. Keep the cutting machine free from residue by means of a vacuum cleaner. Be sure to include the blade guides. Keep the band saw in good condition: If it is not to be used for a long time, put the tool away in its original packing in a damp-free place. In this case it is advisable to loosen the blade so as not to keep it under tension unnecessarily.

SPECIFICATIONS

ITEM	SPECIFICATIONS	ITEM	SPECIFICATION
Voltage	240 Volts	Base Material	Aluminium
Motor	1650W	Bow Material	Aluminium
Cutting Capacity 90 °	Round Bar 170mm Rectangle 170 x 170mm	Blade Speed	30 - 80 m/min
Cutting Capacity 45 °	Round Bar 125mm Rectangle 125 x 125mm	Dimension	1100 mm x 550 mm x 600 mm
Cutting Capacity 60 °	Round Bar 75mm Rectangle 75 x 70mm	Packing	1040 mm x 490 mm x 565 mm
Blade Size	2035mm x 0.9 x 19	Noise	62 db Approximately

SPARE PARTS SECTION

The following section covers the spare parts diagrams and lists that were current at the time this manual was originally printed. Due to continuous improvements of the machine, changes may be made at any time without notification.

HOW TO ORDER SPARE PARTS

1. Have your machines **model number, serial number & date of manufacture** on hand, these can be found on the specification plate mounted on the machine
2. A scanned copy of your parts list/diagram with required spare part/s identified
3. Go to www.machineryhouse.com.au/contactus and fill out the enquiry form attaching a copy of scanned parts list.



OPERATION MANUAL

WIRING DIAGRAM

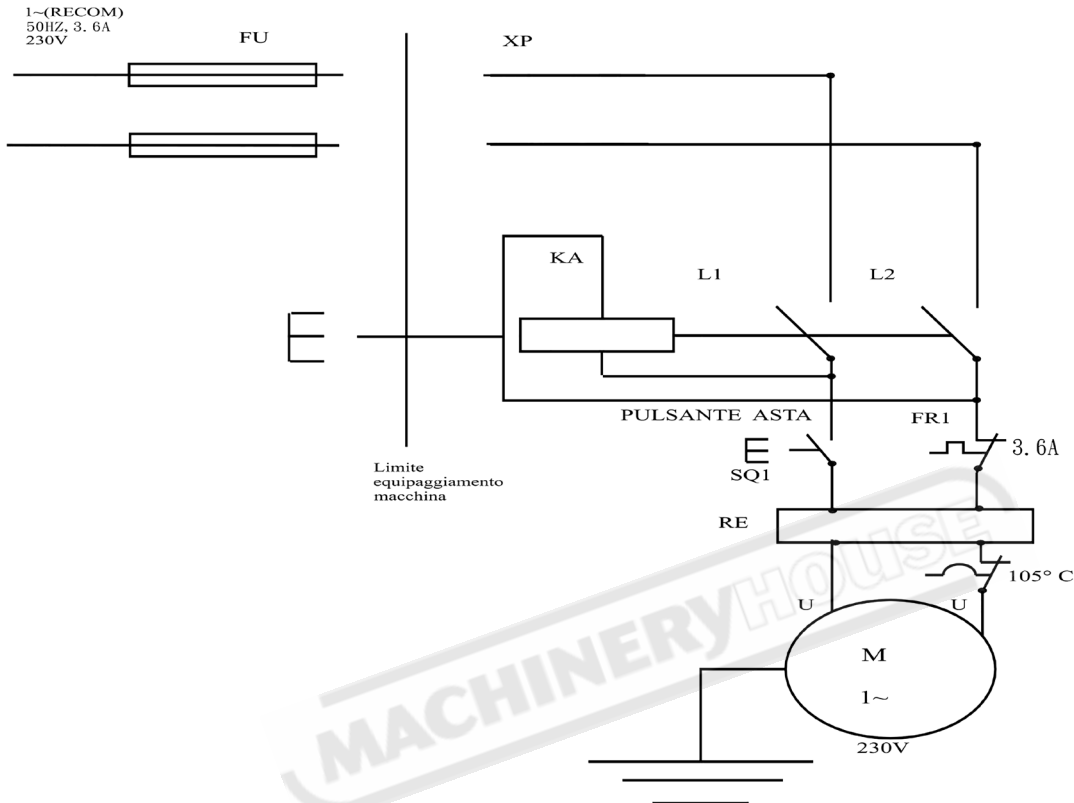

KA	Protecteur CE
SB1	Interrupteur d'arret (OFF)
SB2	Interrupteur general (ON)
XP	Cable d'alimentation
SQ1	Interrupteur marche-arret
M	Moteur 1650W
FR1	Protecteur termique
RE	Inverter

Replacement Motor Brushes
 Order Code: 3BB0099 (Set of 2)



OPERATION MANUAL

SPARE PARTS

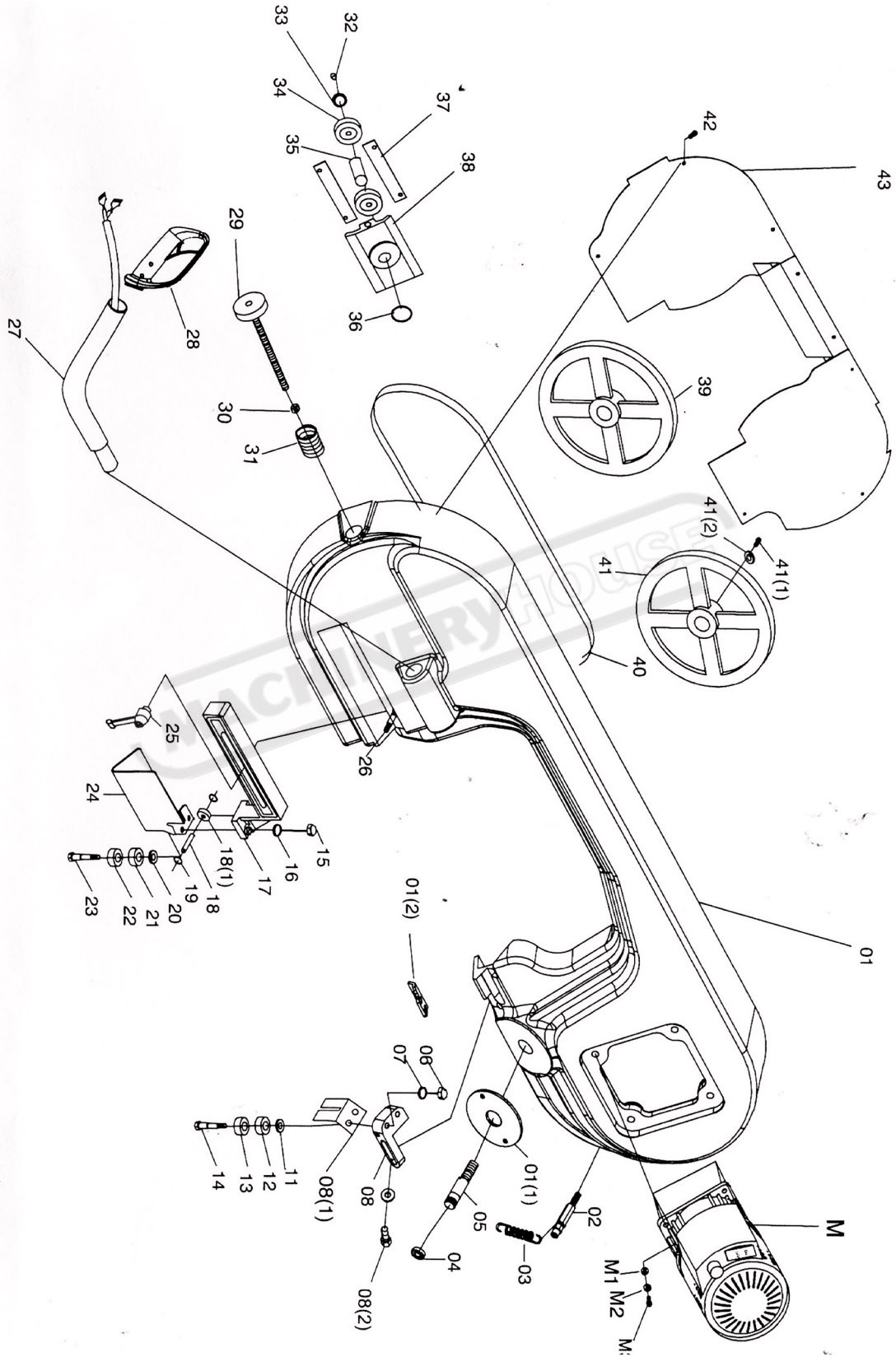

SPARE PARTS Cont.

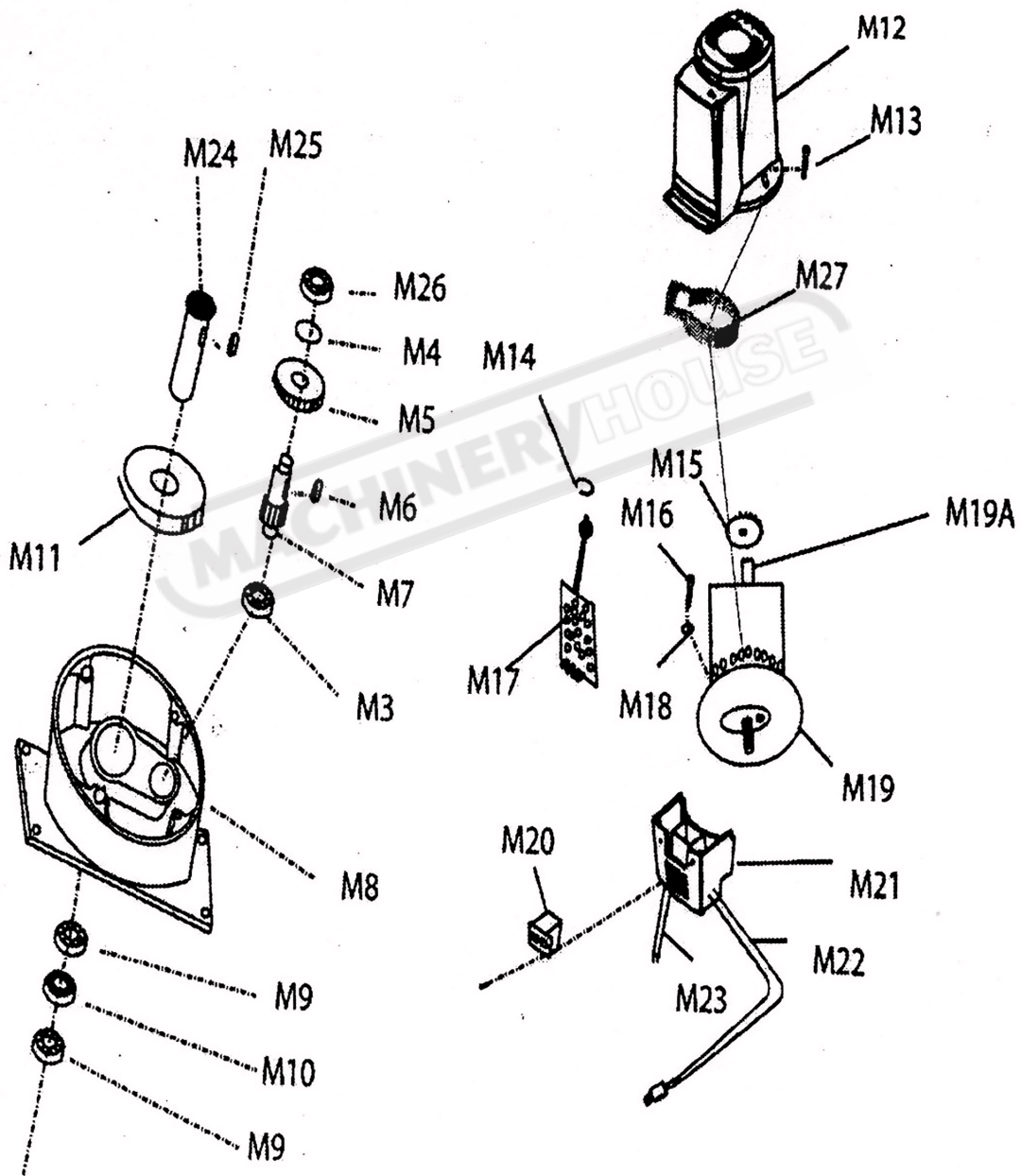



OPERATION MANUAL

SPARE PARTS Cont.

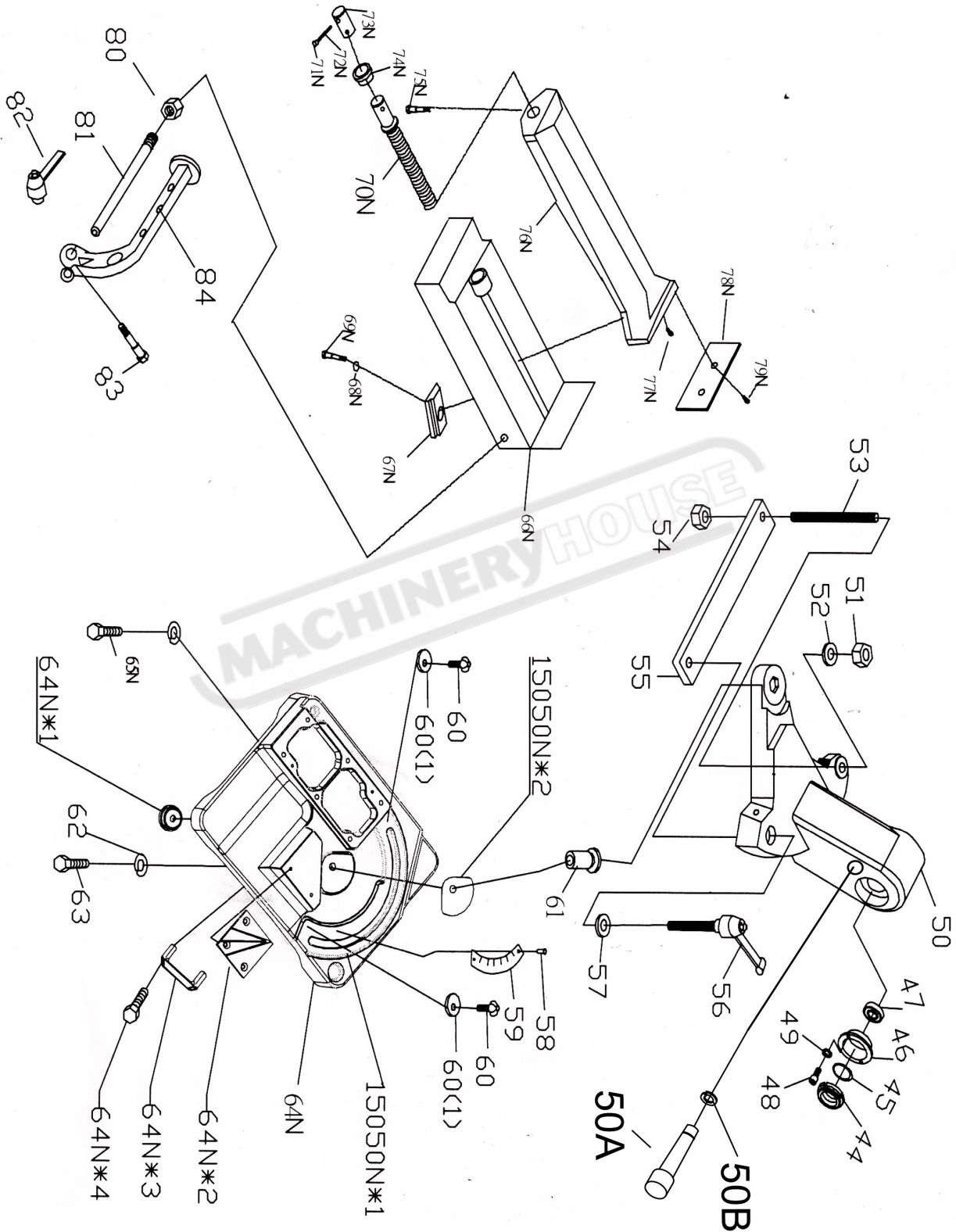



OPERATION MANUAL

SPARE PARTS LIST

No.	Qty.	Description	No.	Qty.	Description	No.	Qty.	Description
1	1	Body frame	42	6	Screw	81	1	Rod stock stop
1A	3	Bow saw plate	43	1	Body cover	82	1	Bolt
1A*1	1	Angle plate	44	1	Nut	83	1	Screw
2	1	Spring axis	45	1	Cover	84	1	Stop Bracket
3	1	Spring	46	1	Bushing	M	1	Motor
4	1	32004 bearing	47	1	32004 bearing	M1	1	Screw
5	1	Axis	48	1	Screw	M2	1	Spring Washer
5A	1	Shaft fixed plate	50	1	Miter	M3	1	Bearing 607
6	2	Nut	15050*1	1	Shaft	M4	1	Stalls circle
7	2	Washer	50N*1	1	Miter plate	M5	1	Gear
8	1	Fixed blade guide plate	50N*2	1	Miter plate	M6	1	Key
8(1)	1	Chip Fence	51	1	Nut	M7	1	Gear shaft
9	2	Screw	53	1	Screw	M8	1	Gear box
11	2	Bushing for arm	54	1	Nut	M9	2	Bearing
12	2	Bearing	55	1	Plate	M10	1	Oil seal
13	2	Bearing	56*1	1	Bolt	M11	1	Gear
14	2	Bias axis	57	1	Washer	M12	1	Up cover
15	2	Nut	58	1	Screw	M13	1	Screw 4X45mm
16	2	Washer	59	1	Scale	M14	1	Nut
17	1	Arm	60	1	Screw	M15	1	Fan
18	2	Pin	60(1)	1	Washer	M16	1	Screw
18(1)	2	Bearing	61N	1	Bushing	M17	1	Electrical board
19	2	Washer	62	1	Washer	M18	1	Oil seal
20	2	Bushing for arm	63	1	Screw	M19	1	Gear plate
21	2	Bearing	64N	1	Base	M19A	1	Motor shaft
22	2	Bearing	64*1	4	Rubber	M19B	1	Motor
23	2	Bias axis	64*2	1	Base plate	M20	1	Switch
24	1	L. blade guard	64*3	2	Handle	M21	1	Down cover
25	1	Bolt	64N*4	8	Screw	M22	1	Plug
26	1	Screw	65N	1	Screw	M23	1	Handel wire
27	1	Handle Shelf	66N	1	Fence Base	M24	1	Main shaft
28	1	Handle	67N	1	Locking seat	M25	1	Key
29	1	Handle Wheel	68N	1	Washer	M26	1	Bearing
30	8	Washer	69N	1	Screw	M27	1	Middle plastic cover
31	2	Screw	70N	1	Acme Screw		1	Polystyrene
32	1	Screw	71N	1	Knob		1	Carton
33	1	Washer	72N	1	Handle Rod			
34	2	Bearing	73N	1	Shaft Bushing			
35	1	Blade sheet shaft	74N	1	Bushing			
36	1	Washer	75N	1	Screw			
37	2	Block	76N	1	Vise			
38	1	Block blade tension	77N	1	Screw			
39	1	Return flywheel	78N	1	Vise plate			
40	1	Saw blade	79N	1	Screw			
41	1	Motor flywheel	80	1	Nut			



WARNING

General Machinery Safety Instructions

Machinery House
requires you to read this entire Manual before using this machine.

- 1. Read the entire Manual before starting machinery.** Machinery may cause serious injury if not correctly used.
- 2. Always use correct hearing protection when operating machinery.** Machinery noise may cause permanent hearing damage.
- 3. Machinery must never be used when tired, or under the influence of drugs or alcohol.** When running machinery you must be alert at all times.
- 4. Wear correct Clothing.** At all times remove all loose clothing, necklaces, rings, jewelry, etc. Long hair must be contained in a hair net. Non-slip protective footwear must be worn.
- 5. Always wear correct respirators around fumes or dust when operating machinery.** Machinery fumes & dust can cause serious respiratory illness. Dust extractors must be used where applicable.
- 6. Always wear correct safety glasses.** When machining you must use the correct eye protection to prevent injuring your eyes.
- 7. Keep work clean and make sure you have good lighting.** Cluttered and dark shadows may cause accidents.
- 8. Personnel must be properly trained or well supervised when operating machinery.** Make sure you have clear and safe understanding of the machine you are operating.
- 9. Keep children and visitors away.** Make sure children and visitors are at a safe distance for you work area.
- 10. Keep your workshop childproof.** Use padlocks, Turn off master power switches and remove start switch keys.
- 11. Never leave machine unattended.** Turn power off and wait till machine has come to a complete stop before leaving the machine unattended.
- 12. Make a safe working environment.** Do not use machine in a damp, wet area, or where flammable or noxious fumes may exist.
- 13. Disconnect main power before service machine.** Make sure power switch is in the off position before re-connecting.
- 14. Use correct amperage extension cords.** Undersized extension cords overheat and lose power. Replace extension cords if they become damaged.
- 15. Keep machine well maintained.** Keep blades sharp and clean for best and safest performance. Follow instructions when lubricating and changing accessories.
- 16. Keep machine well guarded.** Make sure guards on machine are in place and are all working correctly.
- 17. Do not overreach.** Keep proper footing and balance at all times.
- 18. Secure workpiece.** Use clamps or a vice to hold the workpiece where practical. Keeping the workpiece secure will free up your hand to operate the machine and will protect hand from injury.
- 19. Check machine over before operating.** Check machine for damaged parts, loose bolts, Keys and wrenches left on machine and any other conditions that may effect the machines operation. Repair and replace damaged parts.
- 20. Use recommended accessories.** Refer to instruction manual or ask correct service officer when using accessories. The use of improper accessories may cause the risk of injury.
- 21. Do not force machinery.** Work at the speed and capacity at which the machine or accessory was designed.
- 22. Use correct lifting practice.** Always use the correct lifting methods when using machinery. Incorrect lifting methods can cause serious injury.
- 23. Lock mobile bases.** Make sure any mobile bases are locked before using machine.
- 24. Allergic reactions.** Certain metal shavings and cutting fluids may cause an allergic reaction in people and animals, especially when cutting as the fumes can be inhaled. Make sure you know what type of metal and cutting fluid you will be exposed to and how to avoid contamination.
- 25. Call for help.** If at any time you experience difficulties, stop the machine and call you nearest branch service department for help.



Metal Cutting Bandsaw Safety Instructions

Machinery House
requires you to read this entire Manual before using this machine.

- 1. Maintenance.** Make sure the bandsaw is turned off and disconnect from the main power supply and make sure all moving parts have come to a complete stop before any inspection, adjustment or maintenance is carried out.
- 2. Bandsaw Condition.** Bandsaw must be maintained for a proper working condition. Never operate a bandsaw that has damaged or worn parts. Scheduled routine maintenance should be performed on a scheduled basis.
- 3. Blade Condition.** Never operate a bandsaw with a dull, cracked or badly worn blade. Before using a bandsaw inspect blades for missing teeth and cracks.
- 4. Replacing Blade.** Make sure teeth are facing the correct direction. Wear gloves to protect hands and wear safety glasses to protect your eyes.
- 5. Hand Hazard.** Keep hands and fingers clear from the line of cut of the blade and offcuts workpieces. Hands can be crushed in vice or from falling machine components and cut by the blade.
- 6. Leaving a bandsaw Unattended.** Always turn the bandsaw off and make sure all moving parts have come to a complete stop before leaving the bandsaw. Do not leave bandsaw running unattended for any reason.
- 7. Avoiding Entanglement.** Blade guard must be used at all times. Remove loose clothing, belts, or jewelry items. Never wear gloves while machine is in operation. Tie up long hair and use the correct hair nets to avoid any entanglement with the bandsaw moving parts.
- 8. Understand the machines controls.** Make sure you understand the use and operation of all controls.
- 9. Power outage.** In the event of a power failure during use of the bandsaw, turn off all switches to avoid possible sudden start up once power is restored.
- 10. Work area hazards.** Keep the area around the bandsaw clean from oil, tools, chips. Pay attention to other persons in the area and know what is going on around the area to ensure unintended accidents.
- 11. Workpiece Handling.** Workpieces must be supported with table, vice, roller conveyor/stands, or other support fixtures. Unsupported workpieces may cause the machine to tip over and fall. Flag long pieces of material to avoid tripping hazards. Never hold a workpiece with your hands during the cut process.
- 12. Hearing protection and hazards.** Always wear hearing protection as noise generated from bandsaw blade and workpiece vibration, material handling, and power transmission can cause permanent hearing loss over time.
- 13. Hot surfaces.** Workpieces, machine surfaces and chips become hot due to friction and can burn you.
- 14. Starting position.** Never turn the bandsaw on when the blade is resting on the workpiece.
- 15. Guards.** Do not operate bandsaw without the blade guard in place or with the doors open. Ensure all guards removed to do maintenance or change blades on the machine are refitted correctly in place before the machine is used again.
- 16. Call for help.** If at any time you experience difficulties, stop the machine and call your nearest branch service department for help.

PLANT SAFETY PROGRAM

NEW MACHINERY HAZARD IDENTIFICATION, ASSESSMENT & CONTROL

Metal Cutting Bandsaw

Developed in Co-operation Between A.W.I.S.A and Australia Chamber of Manufactures
This program is based upon the Safe Work Australia, Code of Practice - Managing Risks of Plant in the Workplace (WHSA 2011 No10)



Item No.	Hazard Identification	Hazard Assessment	Risk Control Strategies <small>(Recommended for Purchase / Buyer / User)</small>
A	ENTANGLEMENT	HIGH	Eliminate, avoid loose clothing / Long hair etc.
B	CRUSHING	LOW	Secure & support Long / heavy material
C	CUTTING, STABBING, PUNCTURING	MEDIUM	Blade guards should always be in the closed position before starting machine. Blade guide system should be adjusted to suit material width. Wear gloves when changing blades. Isolate main power switch before changing blade, cleaning or adjusting. If blade breaks do not open door until both wheels have stopped. Check blade tracking before starting.
D	SHEARING	MEDIUM	Make sure all guards are secured shut when machine is on. Isolate power to machine prior to changing belts or maintenance.
F	STRIKING	LOW	Support long heavy jobs and stand clear of offcuts. Stand clear of machine when in operation. Remove all loose objects around moving parts. Wear safety glasses
H	ELECTRICAL	MEDIUM	All electrical enclosures should only be opened with a tool that is not to be kept with the machine. Machine should be installed & checked by a Licensed Electrician.
O	OTHER HAZARDS, NOISE.	LOW	Wear hearing protection as required.
Plant Safety Program to be read in conjunction with manufactures instructions			



www.machineryhouse.com.au



www.machineryhouse.co.nz

Authorised and signed by:
Safety officer: 
Manager: 

Revised Date: 12th March 2012